

**CODE NUMBER**

3362109

**DESCRIPTION**

4" Trim Plate, Plug Adapter Power Supply, Back-Check Tee, Polished Chrome Finish, 2.2 gpm, Laminar Spray, Infrared Sensor, Sloan® Hardwired-Powered Deck-Mounted Gooseneck Body.

**DETAILS**

- Flow Rate: 2.2 gpm (8.3 Lpm) (2.2GPM)
- Spray Type: Laminar (LAM)
- Sensor Type: Infrared
- Mounting Type: Single Hole
- Trim Plate: 4" (102mm) (4)
- Power Supply: Plug Adapter (PLG)
- Temperature Mixer: Back-Check Tee (TEE)
- Finish: Polished Chrome (CP)
- Factory Default Timeout: 30 seconds
- Factory Default Gallons per Cycle: 1.1

**FEATURES**

Commercial Grade, ADA Compliant, Electronic, Sensor-Activated, Brass Gooseneck Hand Washing Faucet with the following features:

- Adjustable Infrared Sensor Range
- 36" (914 mm) Long Sensor Cable
- 24" (610 mm) Long Flex Hose
- Filtered Solenoid Valve with serviceable Strainer Filter
- Includes Four (4) AA-size Batteries
- Includes appropriate Mounting Hardware

**ELECTRICAL SPECIFICATIONS**

- Battery Life: 2 years 8,000 cycles/month
- Timeout Adjustment Settings: 30s

**VIDEOS**

- ▶ SF-2100/2150/SF-2200/2250/SF-2300/2350/SF-2400/2450 Parts Breakdown
- ▶ SF-2100/2150/SF-2200/2250/SF-2300/2350/SF-2400/2450 Module Replacement
- ▶ SF-2100/2150/SF-2200/2250/SF-2300/2350/SF-2400/2450 Battery Replacement- Sensor Range Adjustment

**DOWNLOADS**

- [SF Series Installation Instructions](#)
- [SF Series \(FR\) Installation Instructions](#)
- [SF Series \(SP\) Installation Instructions](#)
- [SFP 35-A Installation Instructions](#)
- [Trim Plate Guide](#)
- [Sloan 2100/2150 Repair and Maintenance Guide](#)
- [Additional Downloads](#)

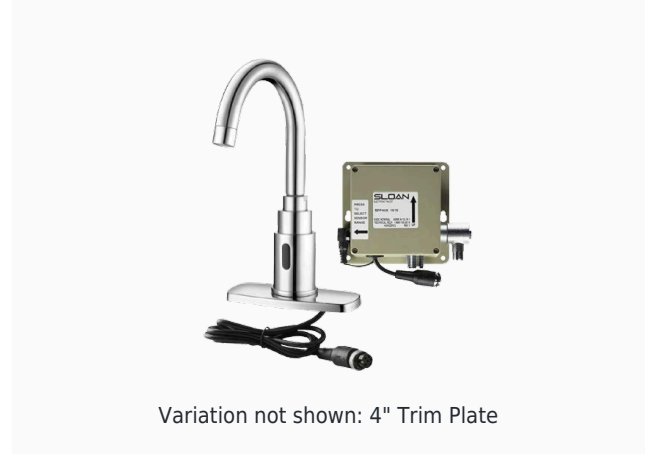

Variation not shown: 4" Trim Plate

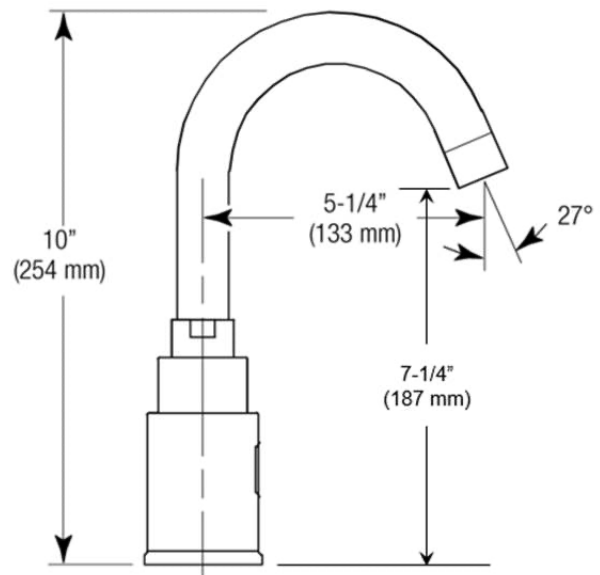

**COMPLIANCES & CERTIFICATIONS**



(ADA Compliant, ASME A112.18.1 Compliant, cUPC Certified, UPC Certified, UPC Low Lead Compliant, cUPC Low Lead Compliant, EPD, HPD, IAPMO, WaterSense Listed, NSF-61, Proposition 65, TAS, WELL Building Standard)

**NOTES**

All information contained within this document subject to change without notice.

Looking for other variations of the SF-2200 product? [View the general spec sheet with all options.](#)

Find a matching soap dispenser for this faucet.  
Find a compatible sink for this faucet.

**WARRANTY**

[View Warranty Information](#)

**ROUGH-IN**

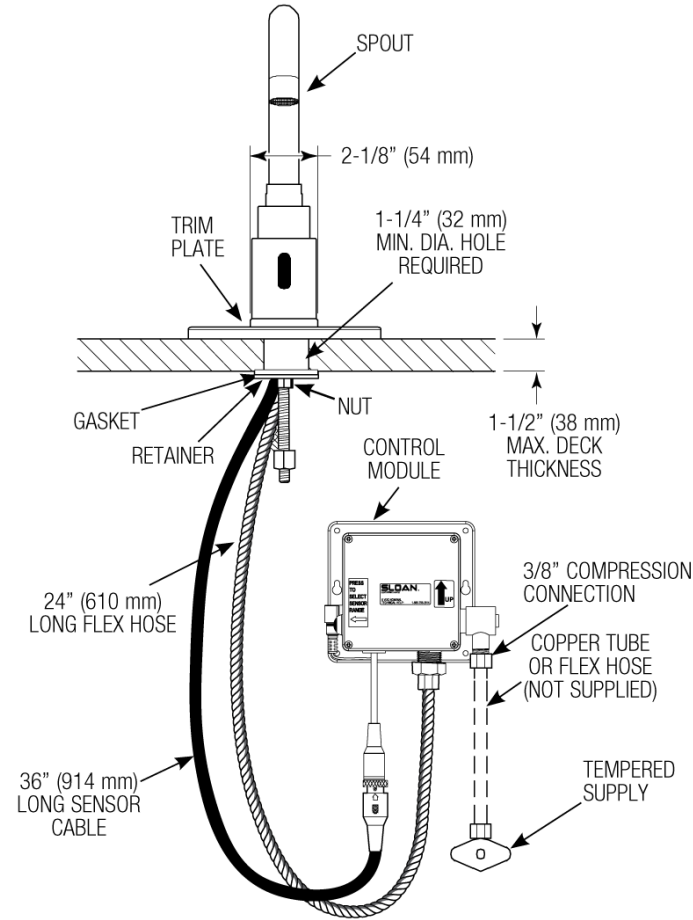

**HOT AND COLD WATER SUPPLY APPLICATIONS**  
(SPECIFY IN MODEL VARIATION)

